

Operating Instructions

Thank you very much for choosing SLIK DOLLY- II .

The SLIK Corporation has designed your dolly to be a sturdy, rugged, dependable product that will provide you with many years of satisfactory use.

Please take a few moments to read this operating instruction carefully before use so that you can take full advantage of your dolly's many fine features. Retain this operating instruction in case you might want to refer back to it.

⚠ Caution

This caution icon refers to information pertaining to important safety procedures in preventing injuries, or damages which may occur as a result of mishandling this product.

🚫 Prohibition

This prohibited icon refers to information pertaining to prohibited contents. Please refer to instructions closely to avoid accidents.

Specification

Folded length	580mm (23")
Max. diameter	1,020mm (40 1/6")
Max. operating height	155mm (6")
Weight	4,500g (9lbs)

K405

Components

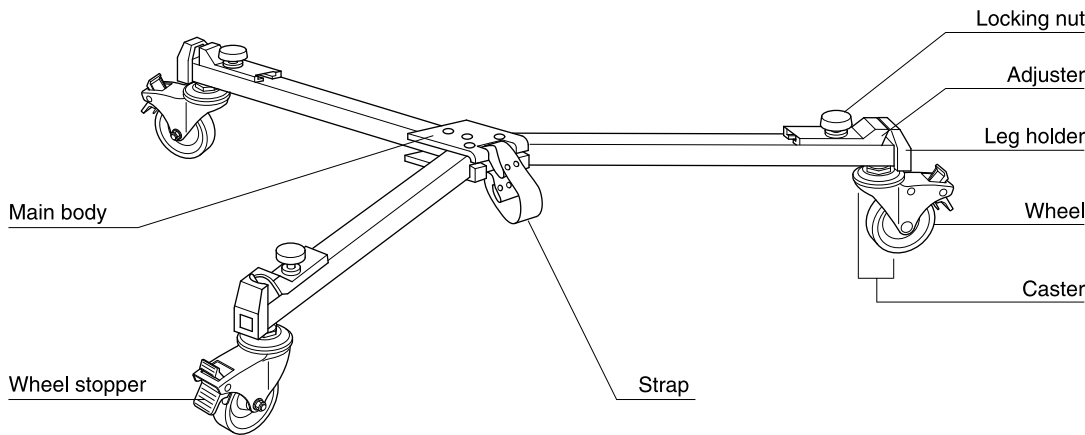

For your safety

1. Use the dolly at horizontal surface.
2. Do not take off your hand from a tripod on the dolly while the tripod system is being moved.
3. Make sure all the wheel stoppers are locked when you leave from the dolly with a tripod on.
4. Do not load articles on the center of the dolly while all tubes are opened.

How to open

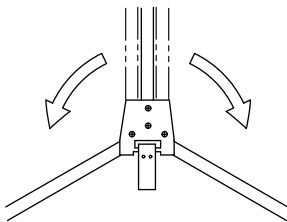

Open the tubes fully until they hit the Nodal Point.

How to set up

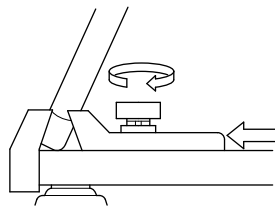

Loosen the Locking nut first, then join with Adjuster for fixing firmly.

How to stop the wheel moving

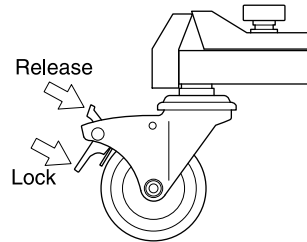

Wheel stopper for the dolly II can be fixed of rotating axis and rolling axis at the same time.

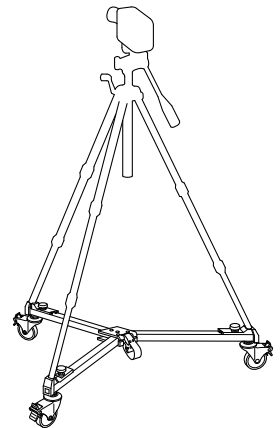

Care of the DOLLY

- DO NOT apply any grease or oil to this product.
- Clean with a mild detergent and a soft cloth only.
- DO NOT use close to flame. Avoid extreme heat.

